

MINIMASTER Analogue Output Module For CANopen IL 5507



Your Advantages

- Compact structure
- easy installation

Features

- For installation in consumer units or industrial cabinets
- Space saving with 2 analogue outputs at 35 mm width required space not more then for 2 standard line circuit breakers
- 2 analogue outputs, optionally with each 2 x 0 ... 10 V, 2 x 0 ... 20 mA, 2 x -10 V ... +10V oder 2 x 4 ... 20 mA
- 12 bit resolution allows accuracy of $< \pm 0.1 \%$
- Galvanic separation between logic, output and bus guarantees high interference immunity
- No external voltage source necessary for output signal
- Can be used in all CANopen networks due to high data transmission rate up to 1Mbit/s
- Free configuration software CoDeSys
- According to IEC/EN 61 131-2
- CANopen interface according to DS301 version 3.0, DS401
- LED indicators for supply voltage and Bus status

Circuit Diagram

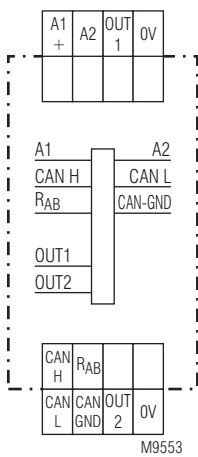

Approvals and Markings



Additional Information about this topic

In addition to the analogue output module IL 5507 Dold offers a complete range of master and slave modules for CANopen field bus systems. Also devices with protection class IP 67 are available. These can be mounted directly at the application without cabinet. This reduces wiring and failures.

Setting and Adjustment

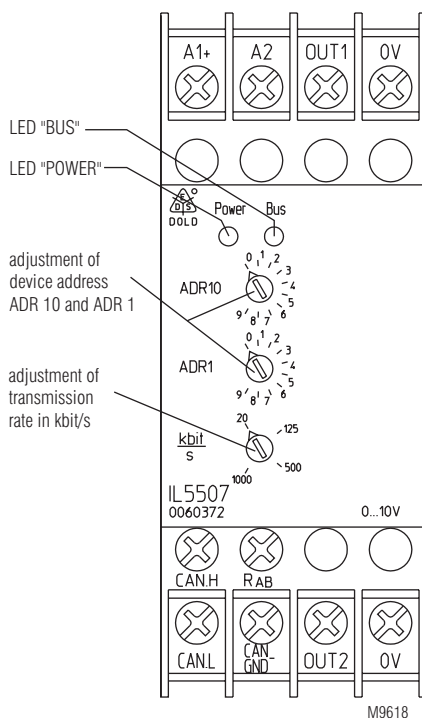

Application

The analogue module IL 5507 for CANopen generates analogue signals e.g. to operate inverters, power- and servo amplifiers. It is designed into a compact installation enclosure and can be used in industry and building automation.

Indication

- | | |
|---------------------|--|
| LED yellow "Power": | on when supply connected |
| LED yellow "BUS": | on, when bus is active, pulsing when bus is inactive |

Set-up Procedure

1. Connect device to CANopen-bus
2. The CANopen bus cable has to be terminated with a 120 Ω resistor on both ends (on DOLD devices this can be done by linking the terminals CAN-H and R_{AB})
3. Adjust transmission speed (e. g. 20 k bit / s)
4. Adjust device addresses
5. Configure bus, e.g. with ProCANopen

The configuration is made with the programming software PN 5501 in conjunction with minimaster IL 5504 / IN 5504 or e.g. with ProCANopen. The corresponding configuration file on CD can be ordered under order no. PN 5501, article no. 0052860

Technical Data

Auxiliary Voltage

Auxiliary Voltage U_H A1/A2: DC 24 V
Voltage range: 0.85 ... 1.2 U_N
Nominal consumption: < 2.0 W at DC 24 V

Output

Output: 2, galvanic separation to bus and supply voltage

Separating potentials: AC 350 V_{eff}

Output current: 0 ... 10 V
0 ... 20 mA

Output voltage: > 1 k Ω for 0 ... 10 V; -10V ... +10 V
< 500 Ω for 0 ... 20 mA; 4 ... 20 mA
< 10 mA for 0 ... 10 V; -10 V ... +10 V

Burden:

Output voltage:

Connection: 2-wire screened

Resolution: 12 bit

Accuracy: < \pm 0.1 % of end of scale value

Temperature coefficient: < 0.01 % of max. scale value

Short circuit current / duration: 20 mA / ∞

CANopen interface

IL 5507.90/1__ : acc. to ISO 11898-1, galvanic separation
screened twisted pair

Wiring: settable 20 K bit/s, 125 K bit/s,
500 K bit/s, 1 M bit/s,

Transmission rate: 20 K bit/s = 2.500 m
125 K bit/s = 500 m
500 K bit/s = 100 m
1 M bit/s = 25 m

Max. length:

General Data

Nominal operating mode: continuous operation

Temperature range: 0 ... + 60°C

EMC

Electrostatic discharge (ESD): 8 kV (air) IEC/EN 61 131-2
HF irradiation: 10 V IEC/EN 61 000-4-6

Fast transients
wires for power supply: 2 kV IEC/EN 61 131-2

Fast transients

Analog output: 0.25 kV IEC/EN 61 131-2

Interference suppression: Limit value class B EN 55 011

Degree of protection

Housing: IP 40 IEC/EN 60 529

Terminals: IP 20 IEC/EN 60 529

Enclosure: thermoplastic with VO behaviour
according to UL Subject 94

Mechanical

operating conditions: EN 61 131-2

Climate resistance: EN 61 131-2

Terminal designation: EN 50 005

Wire connection: 2 x 2.5 mm² solid or
2 x 1.5 mm² stranded ferruled
DIN 46 228-1/-2/-3/-4

Wire fixing: Flat terminals with self-lifting
clamping piece IEC/EN 60 999-1
DIN rail DIN/EN 60 715

Mounting:

Weight: 110 g

Dimensions

Width x height x depth: 35 x 90 x 61 mm

Standard Types

IL 5507.90/100 DC 24 V
Article number: 0060372
• 2 analogue Outputs 0 ... 10 V
• Nominal voltage U_N : DC 24 V

IL 5507.90/110 DC 24 V
Article number: 0060373
• 2 analogue Outputs 0 ... 20 mA
• Nominal voltage U_N : DC 24 V

Ordering Example

IL 5507.90 / _ _ 0 DC 24 V

Auxiliary voltage

0: 2 Outputs 0 ... 10 V
1: 2 Outputs 0 ... 20 mA
2: 2 Outputs -10 V ... +10 V
3: 2 Outputs 4 ... 20 mA

0: CANopen-interface
no galvanic separation
1: CANopen-interface
galvanic separation

Type

Accessories

- CANopen PLC IL 5504
- Input / Output module IN 5509
- Input module, digital IP 5502
- Output module, digital IP 5503
- Input module, analogue IL 5508

Application Example

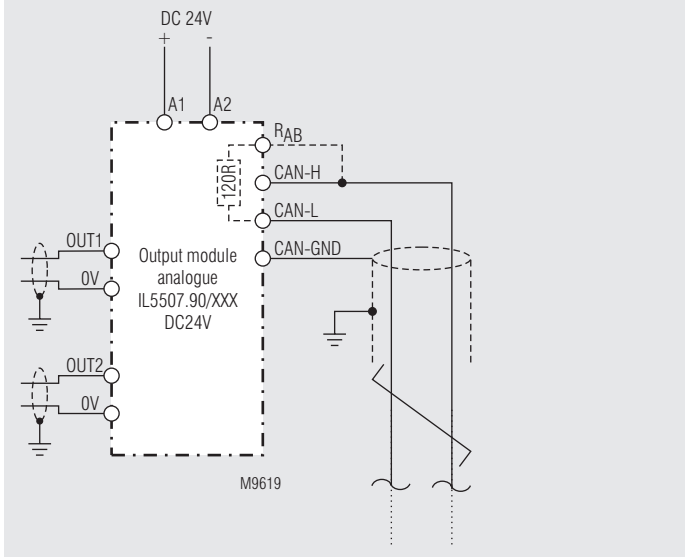

CAN-signals

CAN-H:	CAN_H bus line (dominant high)
CAN-L:	CAN_L bus line (dominant high)
R _{AB} :	Termination resistor 120 Ω
CAN-GND:	reference potential of CAN-transceiver

Notes for wiring

- Mixed networks, or networks that are not galvanically separated
 - CAN-GND is connected between all devices (CIA DRP 303-1).
 - if no 3rd wire is available in the bus cable, the screen of the cable can be used. In this case the screen has to be connected to PE at one point.
- Galvanic separated networks
 - if the networks are completely separated CAN-GND must not be wired (CIA DRP 303-1).
 - The screen is connected to PE.
- An equalisation of potentials between units in far distance has to be provided.
- The CAN-bus must be terminated at the first and last device on the bus with a 120 Ω resistor, e.g. insert a link on terminals R_{AB} and CAN-H.
- Analogue signal wires must be screened. the screen has to be connected to ground near to the input module.
- To achieve proper function, the DIN rail must have a good connection to ground.

Application Example

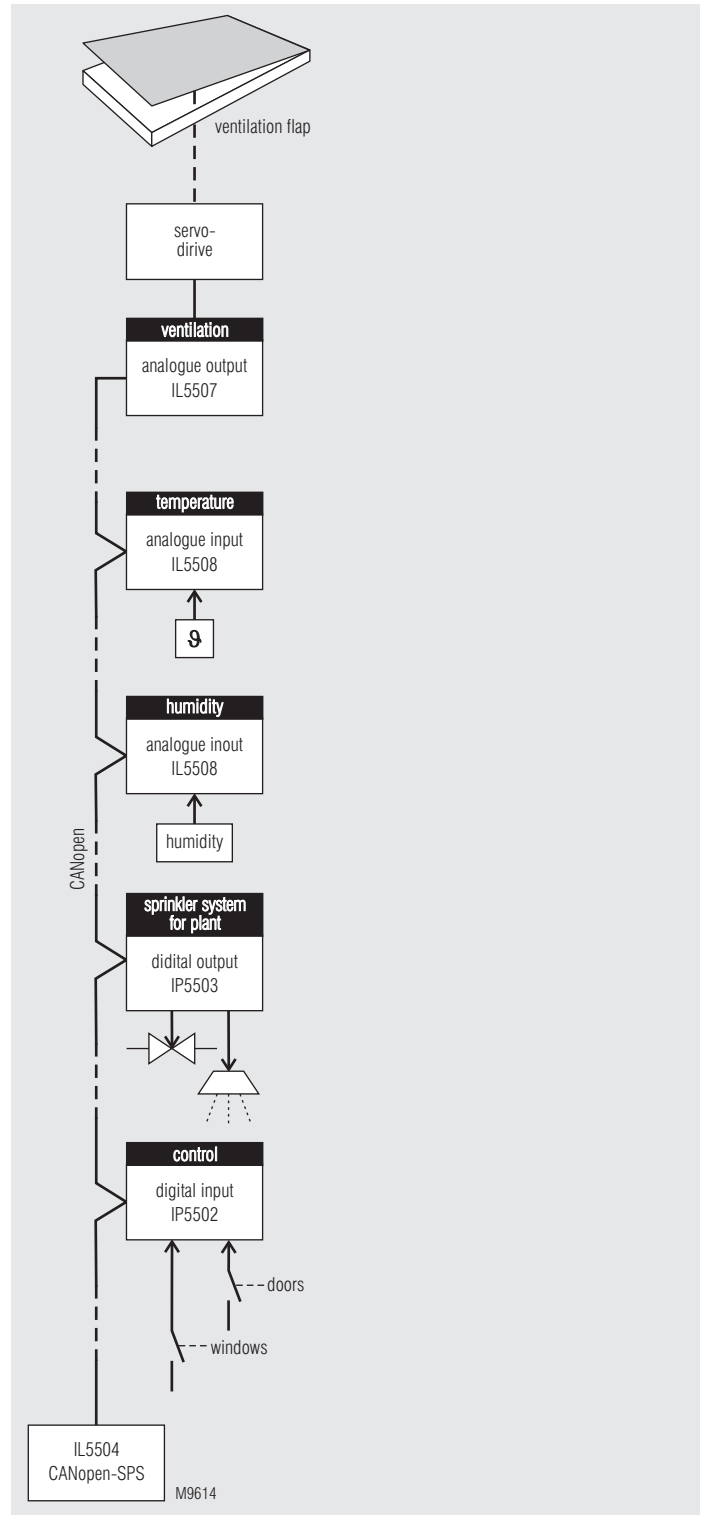

CANopen-application for greenhouses: dependend on temperature- and humidity ventilation flap applications and sprinkler systems for plants in a greenhouse.

